

We Protect You and the Equipment We Manufacture

509 Arbor Drive • Columbia, MO 65201
573.474.9217

HEAVY DUTY CATWALK SUPPORT TOWERS

Catwalks and Manwalks

Hunter's WorldWide manufactures Catwalks and Manwalks to satisfy your requirements. Our products are available in various widths and spans, to support assorted conveyors. The 100% bolted design allowing for ease of assembly in the field.

**Hot Dipped Galvanized
Option, powder coated OSHA Yellow**



Support Towers

The Hunter's WorldWide Support Towers are designed to carry the load of the catwalk. Available in numerous widths to meet the load requirement in four or two leg design, stand alone style or attached to grain bins. The tower can be designed to stand on its own foundation or on the bins.

**Hot Dipped Galvanized
Option, powder coated OSHA Yellow**

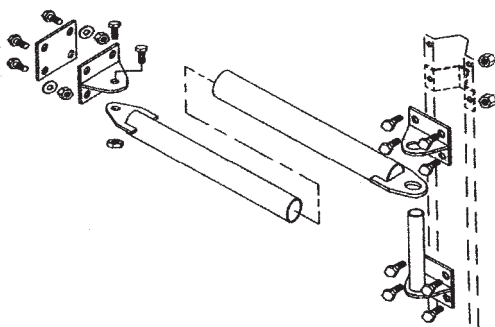
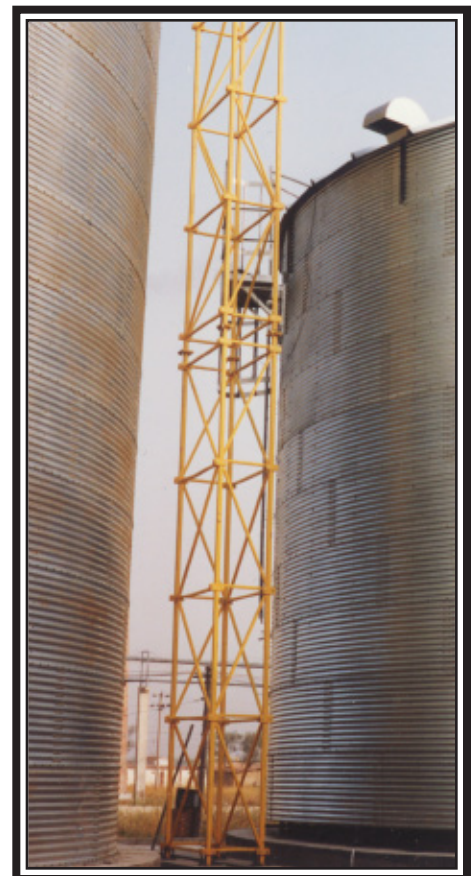

Figure A

Figure A

This is the Hunter Bin Support System designed to allow the Hunter "H" System 2 leg support tower to attach to a Grain bin side stiffener.